

Reg. No. :

--	--	--	--	--	--	--	--	--	--	--	--	--	--	--	--	--	--	--	--

Question Paper Code : 80111

B.E./B.Tech. DEGREE EXAMINATIONS, APRIL/MAY 2019.

Third Semester

Electronics and Communication Engineering

EC 8351 — ELECTRONIC CIRCUITS – I

(Common to Electronics and Telecommunication Engineering)

(Regulation 2017)

Time : Three hours

Maximum : 100 marks

Answer ALL questions.

PART A — (10 × 2 = 20 marks)

1. Define Stability Factor.
2. What are the parameters that the operating point depends upon?
3. Why are common emitter amplifiers more popular?
4. What are the benefits of h-parameters?
5. Write two reasons why a hybrid parameter model is used in small signal analysis.
6. Compare the characteristic of small signal amplifier with large signal amplifier.
7. Why are h-parameters not used at high frequencies?
8. What is meant by gain-bandwidth product?
9. Define ripple factor.
10. Summarize the TUF of HWR and FWR.

PART B — (5 × 13 = 65 marks)

11. (a) What is D.C. load line? How will you select the operating point, explain it using common emitter amplifier characteristics as an example?

Or

- (b) With neat diagrams, explain two bias compensation techniques and state its advantages and disadvantages.

12. (a) Show the ac equivalent circuit of a CE amplifier with voltage divider bias and derive the expression for current gain, voltage gain, input impedance, output admittance and overall current gain.

Or

- (b) Examine the circuit diagram for a differential amplifier using BJT's. Describe its common mode and differential mode operation.
13. (a) Explain the principle of operation of a JFET amplifier? Derive voltage gain, input and output impedance of common source JFET amplifier with a neat circuit diagram of its small signal equivalent circuit.

Or

- (b) Demonstrate the working of MOSFET source follower with its small signal equivalent circuit. Derive its voltage gain, current gain and output impedance.
14. (a) Derive the expression for the short circuit current gain of common emitter amplifier at a high frequency. Define alpha cut-off frequency, beta cut-off frequency and transition frequency and derive their values in terms of the circuit parameters.

Or

- (b) (i) Derive the expression for input conductance (g_{be}) and output resistance (r_o) for hybrid — π common emitter transistor model. (6)
- (ii) Derive the expression for 3dB bandwidth of CE amplifier considering miller effect. (7)
15. (a) (i) Outline the comparison of half wave and full wave rectifier. (7)
- (ii) Summarize the comparison of shunt and voltage regulator. (6)

Or

- (b) Demonstrate the design and working of regulated dc power supply.

PART C — (1 × 15 = 15 marks)

16. (a) Consider the common-emitter BJT amplifier circuit. Assume $V_{CC} = 15, V$
 $\beta = 150, V_{BE} = 0.7 V, R_E = 1 k\Omega, R_C = 4.7 k\Omega, R_1 = 47 k\Omega, R_2 = 10 k\Omega,$
 $R_L = 47 k\Omega, R_s = 100 \Omega.$
- (i) Determine the Q-point. (3)
- (ii) Sketch the DC load-line. What is the maximum (peak to peak) output voltage swing available in this amplifier? (4)

- (iii) Draw the AC equivalent circuit and determine the AC model parameters. (4)
- (iv) Find R_{in} , R_{out} , A_v , A_i . (4)

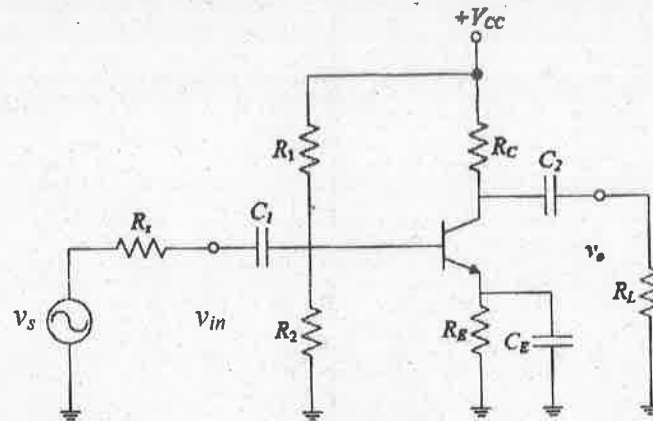

Or

- (b) With neat sketch, elaborate the principle, construction and working of different types of switched mode power supply.

